

PREPARED BY: <i>R. Masaki</i>	DATE: <i>June 3 1994</i>	SHARP	SPEC. No. ED-94038
APPROVED BY: <i>K. Oawa</i>	DATE: <i>June 3, 1994</i>		ISSUE <i>June 3, 1994</i>
			PAGE 9 Pages
		ELECTRONIC COMPONENTS GROUP SHARP CORPORATION	REPRESENTATIVE DIVISION
		SPECIFICATION	OPTO-ELECTRONIC DEVICES DIV.

DEVICE SPECIFICATION FOR

Infrared Light Detecting unit
for Remote Control

MODEL No.

GP1U28Y series

1. This specification sheets include the contents under the copyright of Sharp Corporation ("Sharp"). Please keep them with reasonable care as important information. Please don't reproduce or cause anyone reproduce them without Sharp's consent.
2. Please obey the instructions mentioned below for actual use of this device. Contact a SHARP representative of sales office in advance when you intend to use SHARP devices for any applications other than those applications for general electronic equipment recommend by SHARP at (1).
 - (1) This device is designed for general electronic equipment.
Main uses of this device are as follows;
 - OA equipment .AV equipment
 - Home appliance, . Telecommunication equipment (Terminal), etc.
 - (2) Please take proper steps in order to maintain reliability and safety, in case this device is used for the uses mentioned below which require high reliability.
 - Unit concerning control and safety of a vehicle (air plane, train, automobile etc.)
 - Gas leak detection breaker • Traffic signal • Fire box and burglar alarm box
 - Other safety equipment, etc.
 - (3) Please do not use for the uses mentioned below which require extremely high reliability.
 - Space equipment • Telecommunication equipment (Trunk)
 - Nuclear control equipment . Medical equipment etc.

CUSTOMER'S APPROVAL

DATE

BY

DATE
PRESENTED
BY

T. Matsumura

T. Matsumura,
Department General Manager of
Engineering Dept. ,11
Opto-Electronic Devices Div.
ELECOM Group
SHARP CORPORATION

REFERENCE

1. Application

This specifications applies to the model marked " O " in the following models of infrared light detecting unit for remote control.

The model list of GP 1 U28Y series

Application	Model No.	B.P.F. center frequency (TYP)
	GP 1 U28Y	40 kHz
	GP1U280Y	36 kHz
	GP1U281Y	38 kHz
	GP 1 U282Y	36.7 kHz
	GP1U283Y	32.75 kHz
	GP1U287Y	56.8 kHz

Main application : TV set, VCR, Radio cassette recorder, Stereo

2. Outline

Refer to the attached sheet, Page 7.

3. Ratings and characteristics

Refer to the attached sheet, Page 3 to 6.

4. Reliability

Refer to the attached sheet, Page 8.

5. Incoming inspection

Refer to the attached sheet, Page 9.

REFERENCE

6. Supplement

- 1) This infrared light detecting unit for remote control satisfies each performance requirements in para. 3.5, in the standard optical system in Fig.2.
- 2) This product is built-in photodiode.

7. Notes

- 11 If GP 1 U28Y series is used in wireless remote controllers, please use in accordance with the transmission scheme and the signal format recommended in "Guidance to prevent home appliances with infrared remote control from malfunctions" issued by Japan Association of Electrical Home Appliances (AEHA) in July 1987.
There is a possibility that malfunction may be caused under some conditions, if the different transmission scheme and signal format from the AEHA's is used.
(Ex. signal format without leader signal, or bit structure of smaller duty ratio ($T_H / (T_H + T_L)$), etc.)
- 21 Please use a light emitting unit (remote control transmitter) taking into consideration such factors as the performances, characteristics and operating condition of the light emitting element and the characteristics of this light detecting unit.)
- 31 If the surface of detector is smeared with dust or dirt, it may cause faulty operation. Caution shall be taken to avoid this. And do not touch the detector surface.
If the surface was smeared, wipe it clean with soft cloth. If any solvent is needed, Methyl alcohol, Ethyl alcohol, or Isopropyl alcohol should be used. Please don't carry out washing. Because, after washing the remainder in solvent or flux in this device cause malfunction. Marking on this device is defaced by washing.
- 4 The shield case shall be grounded on the PWB pattern.
(There are two cases that shield case and GND pin continue in the shield case, or doesn't continue in it.)
- 5) It shall not be applied the terminal and case with unnecessary stress.
- 6) Please don't push the detecting side (photodiode) from external.
- 7) In order to prevent static destruction of integrated circuit, human body and soldering iron, etc. shall be grounded.
- 8) The holes and the slits on the light detecting unit shall not be used as the other purpose to maintain its performance.

8. Others

Any doubt as to this specification shall be determined in good faith upon mutual of the both parties.

REVISION

3. Ratings and characteristics

3.1 Schematic

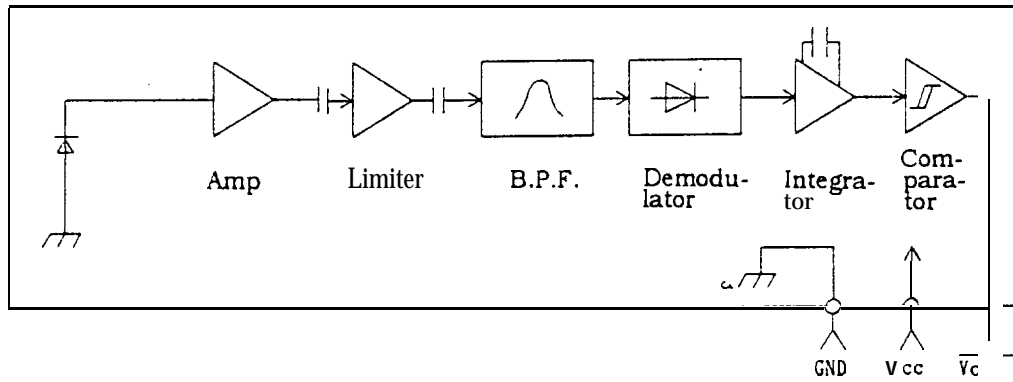

3.2 Absolute maximum ratings

Parameter	Symbol	Ratings	unit
Supply voltage	Vcc	0 to 6.3	v
Operating temperature	Topr	-10 to +70 ※1	°c
Storage temperature	Tstg	-20 to +70	°c
Soldering temperature	Tsol	260 (Soldering time : 5s)	°C

※1) No dew formation

3.3 Recommended operating conditions

Parameter	symbol	Operating condition	unit
Supply voltage	Vcc	4.7 to 5.3	v

REFERENCE
 PAGE 11
 WE

3.4 Electrical characteristics

(Unspecified Ta=25°C, Vcc=+5V)

Parameter	symbol	MIN.	TYP.	MAX.	unit	Remark
Current dissipation	ICC		-	5.0	mA	No input light
High level output voltage	V _{OH}	Vcc-0.5	-	-	V	※2
Low level output voltage	V _{OL}		-	0.45	V	※2
High level pulse width	T ₁	400		800	μs	※2
Low level pulse width	T ₂	400		800	μs	※2
B.P.F. center frequency	f ₀		※3	-	kHz	

※2) The burst wave as shown in the figure on the right shall be transmitted by the transmitter shown in Fig. 1. However, the carrier frequency of transmitter is same as ※3. Measuring shall be 100pulse or later after starting the transmission.

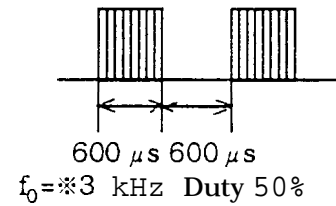

※3) B.P.F. center frequency : f₀ of each model is shown in the list below.

Model No.	B.P.F. center frequency (kHz)
GP1 U28Y	40
GP1U280X	36
GP1U281X	38
GP 1 U282X	36.7
GP 1 U283X	32.75
GP1U287X	56.8

REFERENCE

3.5 Performance

The output signal of this light detecting unit shall satisfy the following requirements with the transmitter shown in Fig. 1 used in the standard optical system in Fig.2.

3.5.1 Characteristics of linear reception distance

The output signal shall satisfy the electrical characteristic requirements in para. 3.4 at $L=0.2$ to 8m , ($\ast 4$) $E_e < 10 \text{ lx}$, $\phi = 0^\circ$ in Fig.2.

3.5.2 Characteristics of sensitivity angle reception distance'

The output signal shall satisfy the electrical characteristic requirements in para. 3.4 at $L=0.2$ to 6m , ($\ast 4$) $E_e < 10 \text{ lx}$, $\phi \leq 30^\circ$ in Fig.2.

3.5.3 Characteristics of anti-outer peripheral light reception distance

The output signal shall satisfy the electrical characteristic requirements in para. 3.4 at $L=0.2$ to 4m , ($\ast 5$) $E_e \leq 300 \text{ lx}$, $\phi = 0^\circ$ in Fig.2.

$\ast 4$) It refers to detector face illuminance.

$\ast 5$) Outer peripheral light source: CIE standard light source A shall be used and placed at 45° from the perpendicular axis at the detector face center.

REFERENCE

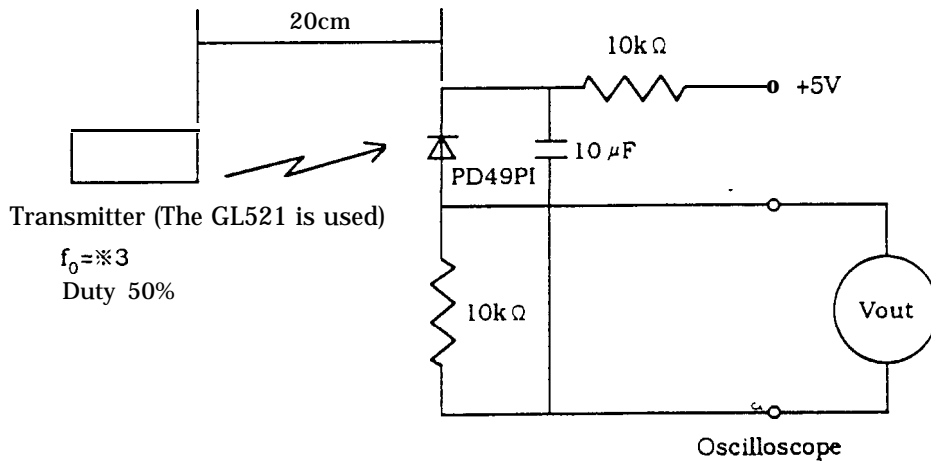

In the figure above, the transmitter shall be set as the output V_{out} will be 40mVpp. Note that the PD49PI in this application is the one with short-circuit current $I_{sc} = 2.6 \mu A$ measured at $E_v = 100 \text{ lx}$. (E_v is the illuminance by CIE standard light source A (tungsten lamp)).

Fig. 1 Transmitter

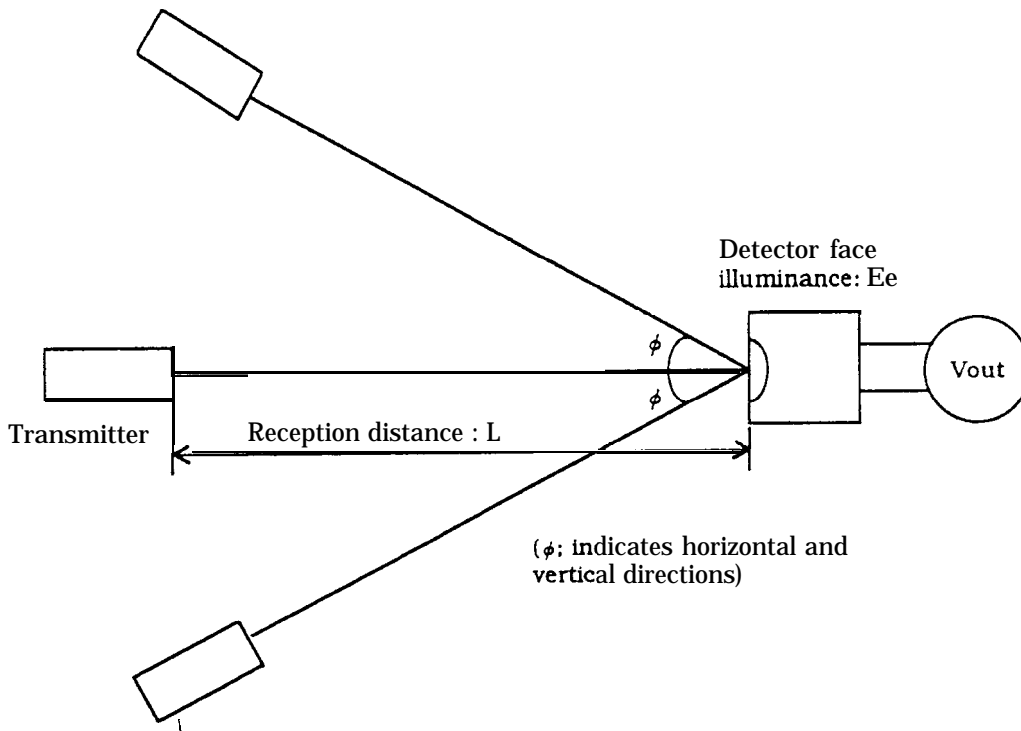

Fig.2 Standard optical system

REFERENCE

4. Reliability

The reliability of products shall be satisfied with items listed below.

Confidence level : 90%
LTPD : 10%/20%

Test Items	Test Conditions	Failure Judgement Criteria	Samples (n) Defective(C)
Terminal strength (Tension)	Weight : 5N{0.5kgf} 30s/each terminal	Performance test requirements and criteria given in para. 3.5 should be satisfied.	n=11, C=0
Terminal strength (Bending)	Weight : 2.5N{0.25kgf} o° -90° -0°* 2 times leach terminal		n=11, C=0
Shock	Acceleration: 1000m/s ² {100G}, 6ms 3directions / 3times		n=11, C=0
Variable frequency vibration	Frequency range: 10 to 55 Hz/sweep 1min. Overall amplitude: 1.5mm X, Y, Z/2h each		n=11, C=0
•High temp. and high humidity storage	Ta=40°C, 90%RH, t=240h		n=22, C=0
•High temp. storage	Ta=70°C, t=240h		n=22, C=0
•Low temp. storage	Ta=-20°C, t=240h		n=22, C=0
•Temperature cycling	1cycle -20°C --70 °c (30min.)(30min.) 20cycles test		n=22, C=0
•Operation life	Ta=70°C, VCC=5V, t=240h		n=22, C=0
Solder heat	260 ±5°C, 5s		n=11, C=0

In the test *mark above, the sample to be tested shall be left at normal temperature and humidity for 2hours after it is taken out of the chamber. (No dew point)

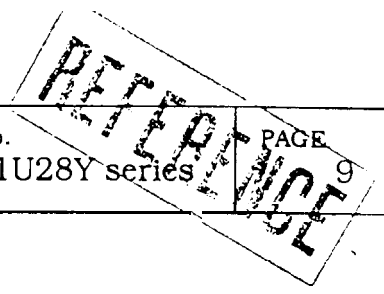

5. Incoming inspection

(1) Inspection lot

Inspection shall be carried out per each delivery lot.

(2) Inspection method

A single sampling plan, normal inspection level II based on MIL-STD-105D shall be applied.

Classification of Defects		Inspection Items	AQL (%)
Major defect	1	Electrical characteristic defect of V_{OH} , V_{OL} , T_1 and T_2 in para. 3.4.	0.4
	2	Distance between signal terminal and shield case (0.2mm or more) (Except for GND terminal)	
	3	It should have no remarkable stains and cracks that give any influence of electrical characteristic on light detecting face.	
Minor defect	1	Transformation of shield case (Satisfying outline dimensions of item 2)	1.5
	2	Stamp, Carved seal (It should be possible to read stamp and carved seal of item 2. Stamp and carved seal should be indicated at fixed position.)	